

BLACK BOX 3

for
PLC-ANALYZER pro 5



BLACKBOX 3

Long-term PLC process data recording
and remote maintenance with PLC-ANALYZER pro 5
Mini-PC for integration in a switching cabinet

User Manual BLACKBOX for PLC-ANALYZER pro 5

© Copyright 1995 - 2017 AUTEM GmbH. All rights reserved. No part of this user manual, including excerpts, may be reproduced, photocopied, or electronically stored without express written permission by AUTEM.

The software described in this manual is subject of a software licensing agreement and may be used only according to the terms of this agreement.

AUTEM GmbH
Dithmarscher Straße 29
D - 26723 Emden
Germany

Telephone +49-4921-9610-0
Telefax +49-4921-9610-96
eMail info@autem.de
http:// www.autem.de

AUTEM issues no guarantee for this manual. This includes both expressly given or tacit guarantees for commercially accepted quality and suitability for a particular use. AUTEM accepts no liability for errors in the manual or for damages that may occur as a result of using or applying this material.

The names of particular software and hardware products mentioned in this book are mostly registered trademarks whose usage is subject to the terms of appropriate law.

We are thankful for any comments, suggestions or ideas you care to write to us.

2nd Edition 2017



WARNING

Errors that can occur in the automated facility endangering humans or causing large-scale material damage must be prevented by additional external measures. These measures (e.g. independent limit monitors, mechanical interlocks) must guarantee safe operation even in the case of dangerous errors.



WARNING

If you use the BLACKBOX within an unprotected network you should install Windows security updates regularly.



WARNING

For some types of signal recording (e. g. cycle-precise acquisition) PLC-ANALYZER pro has to modify the PLC program. An influence of this modification on the behaviour of the PLC can not be eliminated entirely. See driver addendum of the PLC driver for further information.



Caveat emptor

The warranty on BLACKBOX is 12 months. The warranty no longer applies if the product is tampered with, or if the product is not handled properly, or if the product is stored under adverse conditions. The warranty also no longer applies if the device is used in a fashion that does not correspond to the manufacturer's intended use, or if used after wear-and-tear has taken effect, or if used with incorrect current or voltage, or if used after damage by surge, lightning, fire, water (dampness). The warranty no longer applies if the guaranty seal is removed or rendered unreadable.



Non-warranty

In no event shall AUTEM or its suppliers be liable for any damages whatsoever (including without limitation damages through loss of business profits, business interruption, loss of business information or other pecuniary loss) arising out of the use of or inability to use this AUTEM product even if AUTEM has been advised of the possibility of such damages. In any case, AUTEM's entire liability under any provision of this agreement shall be limited to the amount actually paid for the software. This exclusion is not applicable to damages that were caused with intent or culpable negligence on sides of AUTEM. Claims also remain untouched, that are based on inalienable legal rules about product liability.

Table of Contents

1	INTRODUCTION	1-1
1.1	Overview	1-1
1.2	Field of application	1-2
1.3	Performance characteristics	1-2
1.4	Typical operation	1-3
1.5	Help / Support	1-3
2	INSTALLATION	2-1
2.1	Installation	2-1
2.2	LIFE-INDICATOR for external indication of operating status	2-2
2.3	ACTION-CONTACT	2-2
2.4	Installation of additional hardware	2-3
3	STARTING UP AND OPERATION	3-1
3.1	Operation using keyboard, mouse and screen	3-1
3.2	Remote operation of BLACKBOX	3-2
3.2.1	Remote operation via LAN	3-2
3.2.2	Remote operation via Internet	3-4
3.3	Set up the language of operating system	3-5
3.4	Watchdog	3-5
3.5	Control LEDs	3-6
4	OPERATION WITH PLC-ANALYZER PRO 5	4-1
4.1	Creating the project for signal recording	4-1
4.2	Start signal recording	4-2
4.3	Start parameters for PLC-ANALYZER pro 5	4-3
4.4	Reading out recorded signal files	4-4
4.5	Status Messages via REMOTE-STATUS-INDICATOR	4-5
4.5.1	Configure SMS dispatching	4-7
4.5.2	Configure E-mail dispatching	4-7
5	TROUBLESHOOTING (FAQ)	5-1

Table of Diagrams

Fig. 2-1	BLACKBOX dimensions	2-1
Fig. 2-2	Pinout Power Supply	2-2
Fig. 2-3	Floating contact jack (LIFE-INDICTOR)	2-2
Fig. 2-1	SIM-Card Slot LTE-Modem	2-3
Fig. 3-1	Remote LAN connection	3-2
Fig. 4-1	RECORDING LED	4-2
Fig. 4-2	Changing the PLC-ANALYZER pro 5 start parameters	4-4
Fig. 4-3	REMOTE-STATUS-INDICATOR - status messages	4-5
Fig. 4-4	Configure a status message	4-5
Fig. 4-5	SMS settings	4-7
Fig. 4-6	E-mail settings	4-7

1 Introduction

1.1 Overview

The BLACKBOX from AUTEM provides an ultra-compact data acquisition computer for the long-term recording of PLC signals and external electrical values (PLC process data archiving) and also remote maintenance using the PLC-ANALYZER pro 5. Due to its small dimensions, the system can be integrated in a switching cabinet without any problem. The service technician can also conveniently transport the system to the customer in a suitcase (aircraft).

The BLACKBOX can continuously record and archive PLC signals over a longer period of time; typically more than 3 years¹.

The BLACKBOX is connected to the PLC by means supported by the PLC-ANALYZER pro 5, i.e. via connection to the PU interface or an automation network (MPI, PROFIBUS, Industrial Ethernet TCP/IP / PROFINET, Modbus+ ...).

The recording of any electrical signal outside the PLC is also possible by means of the AD_USB-Box (optional, Part.-No. ANA5510E).

The BLACKBOX automatically begins recording signals after being switched on and then archives the requested data.



NOTE

The BLACKBOX is equipped with a special version of PLC-ANALYZER pro 5. This version has special features that make an automated operation possible.

These additional functions includes e. g. the automatic starting of the data acquisition, the supervision of the data acquisition by watchdog functionality, the "LIFE-INDICATOR" contact for external indication of operating status or the possibility of dispatching status messages via "REMOTE-STATUS-INDICATOR".



WARNING

In any case use the „LIFE-INDICATOR“ and, if necessary, also the „ REMOTE-STATUS-INDICATOR “ to supervise the status of the BLACKBOX. This is the only way to recognize possible problems during data acquisition at an early stage.

¹ Depending on the number of recorded signals and signal value changes, the recording capacity may be considerably lower.

1.2 Field of application

- Long-term PLC process data recording
- Failure diagnosis
- Determine cause of production loss / warranty case
- Objective inspection of operating parameters
- Preventive maintenance / Condition monitoring
- System documentation (QA), TPM, QEE, CMS
- PLC Remote-Service

1.3 Performance characteristics

- Massive aluminium case
- Mini-PC (FANless) with Intel Pentium Quadcore 1.6 GHz
- 500 GB SSD / 4 GB RAM
- Dimensions (WxDxH): 185 x 131 x 54 mm / 1,35 kg
- DIN rail mounting / Adapter scope of delivery
- Control-LEDs for RECORDING, PWR, HDD, BAT, LAN
- 4 x USB 3.0 (each 900 mA load-bearing)
- 2 x GbE LAN Port (Gigabit Ethernet)
- Video output: HDMI, DVI-D, DP-Display Port
- 2 x 9 pol. D-Sub RS232/RS422/485 (COM1/COM2),
- 2 x 9 pol. D-Sub RS232 (COM3/COM4)
- 1 x CFast slot
- 2 x Antenna connection for opt. Wi-Fi/3G/LTE-module
- Mini-PCIe slot for opt. addit. modules (Wi-Fi/LTE/...) full-size/half-size / integr. SIM card holder
- Power supply 9 ~ 30 V DC, 25 W
- Plug with cable for ext. DC power supply
- Ext. power supply 100 ~ 240 V AC, 1,5 A, 50 ~ 60 Hz
- Connection for remote PWR-ON/OFF, plug incl.
- Environment: -5°C ~ 55°C operating temperature (ambient with air flow / according to IEC60068-2-1, IEC60068-2-2, IEC60068-2-14),
10 % ~ 95 % rel. humidity – non-condensing
- Signal recording capacity typ. Ø 3 years
- Watchdog monitoring
- External, free floating contact (“LIFE-INDICATOR”) for external indication of operating status (plug is scope of delivery)
- Status messages via E-mail or SMS (opt.) („REMOTE-STATUS-INDICATOR“)
- 3 m LAN patch cable (Cat. 5e) for direct remote control by external PC scope of delivery
- Windows 10 pro (64-Bit) (multi-language)

- Remote control via LAN, WAN, (radio-)modem/internet (VPN) possible
- BLACKBOX-license PLC-ANALYZER pro 5 with PLC-driver Siemens SIMATIC S7 - MPI/PPI/PROFIBUS cycle-precise, incl. documentation; other PLC-driver optional
- Software is completely installed, preconfigured („ready-to-run“)
- CE, FCC Class A
- 48 hour Burn-In, 12 months warranty

1.4 Typical operation

- Create a project with PLC-ANALYZER pro 5 and save it in the BLACKBOX directory
- Switch off BLACKBOX
- Connect BLACKBOX to PLC
- Switch on BLACKBOX
- Check RECORDING-LED (flashes when signal recording is running successfully)
- Process data recording is running ✓

1.5 Help / Support

Should problems occur when using the BLACKBOX for the PLC-ANALYZER pro 5, please read this user manual thoroughly for assistance. Refer especially to chapter 5 *Troubleshooting (FAQ)*. You can also find information and hints unter <http://www.autem.de>

Please contact our technical support if you cannot solve the problem:

Technical Support AUTEM:	
Tel.	+49-(0)4921-9610-0
Fax	+49-(0)4921-9610-96
E-mail	support@autem.de

Please have the following information at hand in addition to an **exact error description**:

- Serial number of the BLACKBOX
- Version and serial number of PLC-ANALYZER pro
- If necessary PLC model and CPU type (e.g. SIMATIC S7-300 / CPU 314) and release number

2 Installation

2.1 Installation

Due to the small dimensions, the BLACKBOX can be installed directly in a switching cabinet. It can be installed either horizontally or vertically. Please refer to *Fig. 2-1* for the exact dimensions.

The BLACKBOX should be protected against vibration and impacts. If necessary, use rubber vibration damper (part-no. ANA9055E) to protect the BLACKBOX from ambient vibration. An electric potential separation is also accomplished thereby.

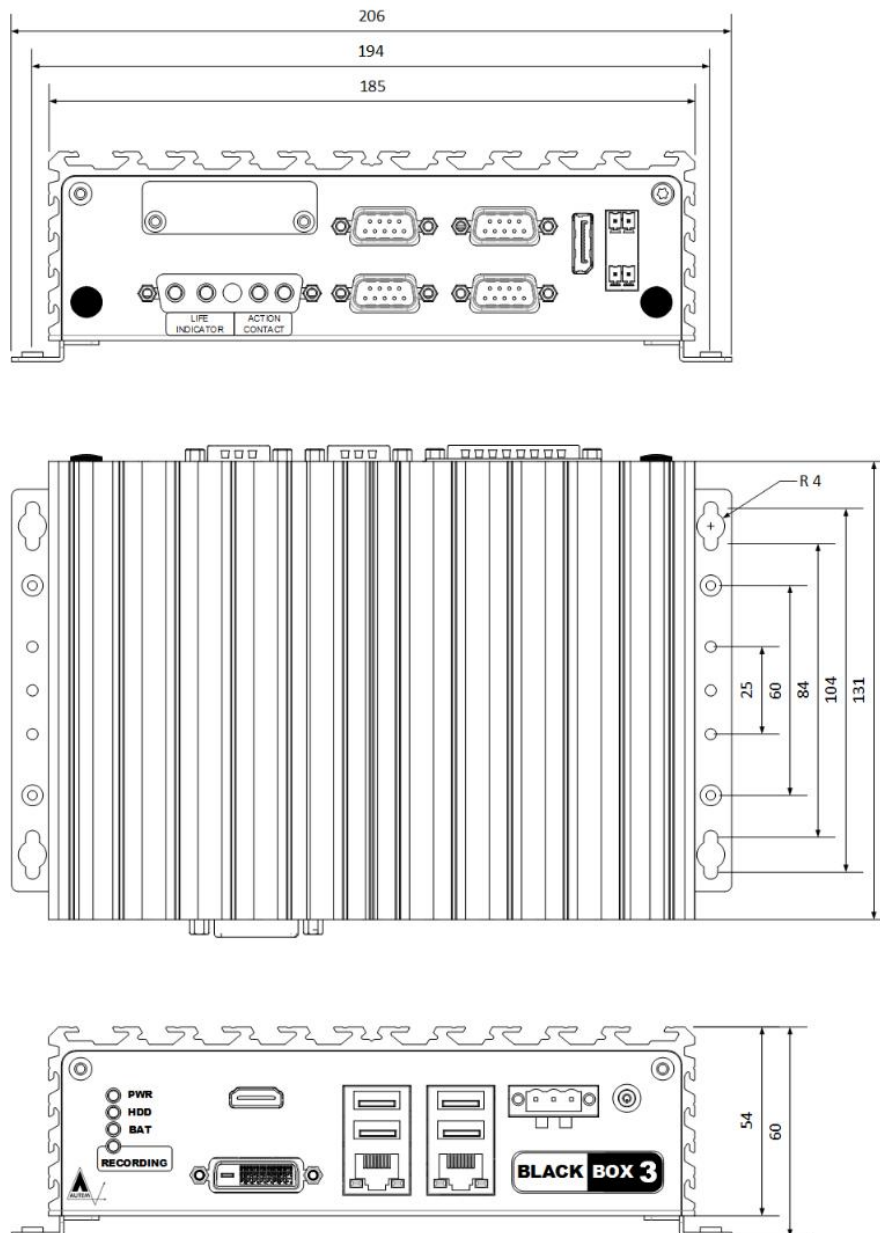

Fig. 2-1 BLACKBOX dimensions

Connect the BLACKBOX to power supply. The BLACKBOX requires a power supply of 9 ~ 30 Volt DC, 25 W. An appropriate DC connector is part of the material supplied. Connect + 9 ~ 30 V of DC to the left pin and DC ground to the middle pin. The right pin is the frame shield.

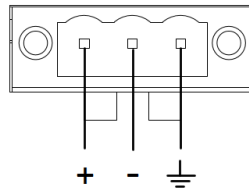

Fig. 2-2 Pinout Power Supply

Alternatively, the power adapter supplied can be used in order to operate the BLACKBOX with 100 ~ 240 Volt AC, 50 ~ 60 Hz.

Now connect the data cable between the BLACKBOX and the PLC.

2.2 LIFE-INDICATOR for external indication of operating status

A floating contact located on the rear of the BLACKBOX provides the option of externally monitoring the operating status of the BLACKBOX. When PLC-ANALYZER pro 5 is operating properly, the LIFE-INDICATOR contact is closed. In the case of an interruption of the recording or computer malfunctions or crashes, the contact opens. The electrical load of the contact is max. 15 W (max. switching voltage is 200 V DC.)

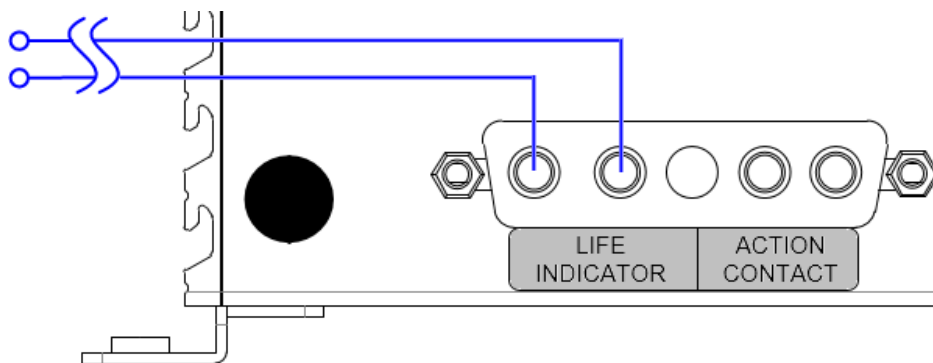

Fig. 2-3 Floating contact jack (LIFE-INDICATOR)

2.3 ACTION-CONTACT

The ACTION-CONTACT is a future function of the BLACKBOX. It is not yet used.

2.4 Installation of additional hardware

Other hardware and software components may need to be connected, depending on the purpose for which the BLACKBOX is being used. Examples of this are UPS for compensation of voltage interruption, a USB-WLAN-adapter, a LTE-modem/router for independent internet access or special software for remote access ("VNC", "TeamViewer" ...).

Usually the BLACKBOX is supplied with the requested software configuration ready installed („ready-to-run“).

2.4.1 Insert SIM card for LTE modem

If you have acquired BLACKBOX 3 with optional LTE modem (Part.-No. LTE1000), it is necessary to put a SIM card with suitable data tariff in the SIM card slot of the LTE modem. The SIM card must have „standard SIM“ format.

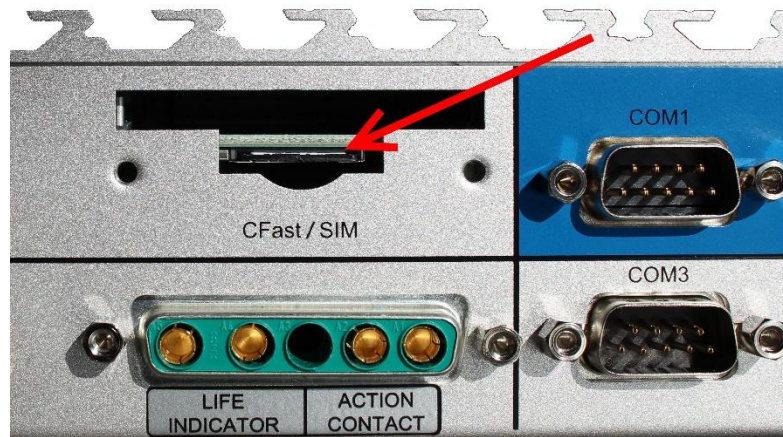

Fig. 2-4 SIM card slot of LTE-Modem

To get access to the SIM card slot, please loose both screws of the protecting cover. Insert SIM card into SIM card slot and close the protecting cover by tightening the screws again.

For further information about using the LTE modem for BLACKBOX 3 remote access via internet please refer to *3.2.2 Remote operation via Internet*.

3 Starting up and operation

There are two methods to start up the BLACKBOX for the first time for configuration purposes. These are explained in the following sections.



NOTE

The BLACKBOX is equipped with a watchdog which monitors the signal recording. In case of an unforeseen interruption of the recording or a computer crash, the BLACKBOX is automatically rebooted because of the watchdog.

See *section 0* for a detailed description of the watchdog and hints for how to disable it.



NOTE

The BLACKBOX clock is defaultly adjusted to CET/MEZ (central european time). Check time and date during putting into operation and adjust manually to local time if necessary, unless it is automatically updated via a time server (Internet).



NOTE

If the BLACKBOX is installed at a place far away from your location, the remote operation (*s. section 3.2 Remote operation of BLACKBOX*) is a good possibility to avoid long access routes for maintenance work. By this means you can also install software updates comfortably or download signal files for analysis.

3.1 Operation using keyboard, mouse and screen

- Connect the keyboard, mouse and screen to the corresponding connections on the BLACKBOX.
- Switch on the BLACKBOX. The power-on button is located on the front panel of the BLACKBOX .
- Press and hold the <Ctrl> key during the entire boot routine as long as the PLC ANALYZER pro 5 is started automatically. This prevent the activation of the Watchdog (also refer to *section 0*).

The BLACKBOX can then be operated as a normal PC running under Windows.



NOTE

The operation system of the BLACKBOX (Windows 10 Professional) is multi-lingual, i. e. the language can be changed during runtime. See *section 0* for further information.

3.2 Remote operation of BLACKBOX

3.2.1 Remote operation via LAN

For remote operation via LAN (network) connect the BLACKBOX by using of enclosed LAN patch cable either to a network hub/switch or directly to an external PC.

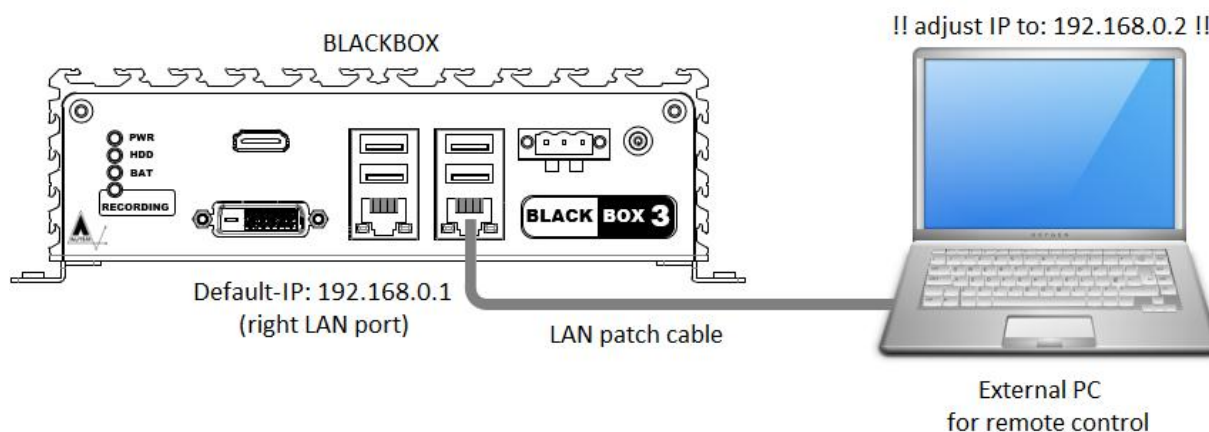

Fig. 3-1 Remote LAN connection

Ensure that the corresponding LAN connection of the BLACKBOX is assigned to an IP address appropriate to your network address scheme.

For remote operation of the BLACKBOX, a PC or Notebook with Win9x / NT / 2000 / XP / Vista / 7 / 8 / 10 is required.

- Establish a connection between the right LAN port of the BLACKBOX and a hub/switch or LAN port of the external PC.
- Set the IP address for the network connection of the PC to 192.168.0.2

Since the hard disk C: of the BLACKBOX is enabled in the network, access is already available to the drive (Explorer / My Network Places), e.g. to copy PLC-ANALYZER pro 5 signal or project files.

- If Windows XP or higher is not installed on the PC, the client for remote operation must be installed on the external PC first of all. Otherwise, skip the following instruction: The client is located on the BLACKBOX's hard disk (`c:\blackbox\client\msrdpcli.exe`). Start the file and follow the instructions in order to install the client.
- Start the remote client:
Enter "Remote Desktop Connection" in windows search bar and start the listed app

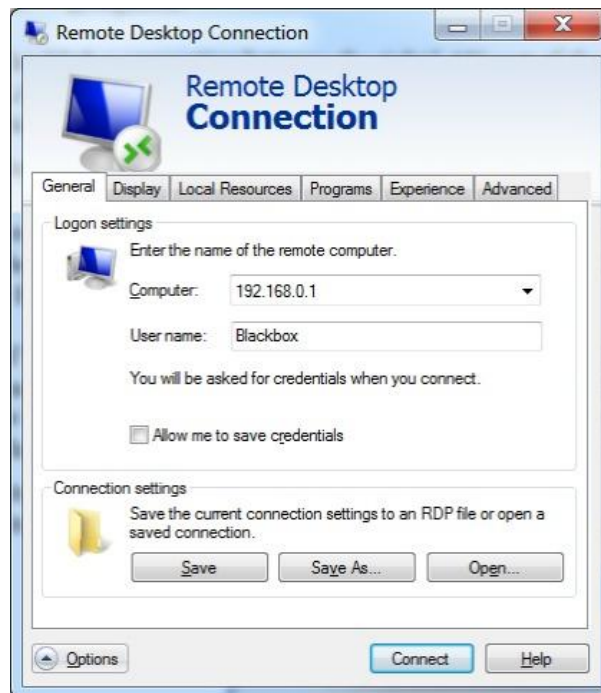

Fig. 3-2 Establish a Remote Desktop Connection

- Enter the *Logon settings*:
 Computer: 192.168.0.1 (IP address of the BLACKBOX)
 User name: Blackbox
- Select *Local Resources / Local devices and resources / More* and select the *Drives* checkbox. This is useful because it enables access to the local drives of the external PC during remote operation of the BLACKBOX.



Fig. 3-3 Enable access to the local drives of the external PC

- Press the *Connect* button. The remote desktop connection is established. Enter the logon password:
Password: Blackbox
- Now the BLACKBOX can be controlled by remote operation.

**NOTE**

If necessary, you can assign any other IP addresses to the LAN connections of the BLACKBOX. Write down any change made to the IP address of the right LAN connection because it is essential for establishing a connection for remote operation. More detailed information on network parameter settings in Windows is available in the Windows Help.

**NOTE**

If necessary, the user name and password of the BLACKBOX (Default: "Blackbox") can be modified under *Start / Control Panel / User Accounts*. Note down any changes to the settings clearly. More information is available in the Windows Help.

3.2.2 Remote operation via Internet

Remote operation of the BLACKBOX can also be performed via Internet. This requires an Internet connection first. Define the necessary settings under *Start / Control Panel / Network and Internet* (Window 7 / 8 / 10).

The Internet connection can be established, for example, via an existing LAN with Internet access, a DSL router, a mobile radio router (UMTS 3G / LTE 4G), etc.

To establish a remote connection over the Internet, the BLACKBOX must be addressable from outside via a static IP address or a DynDNS IP address. If the system can be reached, the remote desktop connection or programs such as "VNC" or corresponding derivatives can be used.

A much easier procedure for remote operation is the use of programs like "TeamViewer". Simply install the "TeamViewer Host" on the BLACKBOX. A static or DynDNS IP address is not necessary for this. Firewalls and proxy servers are no obstacle and are easily tunnelled.

3.3 Set up the language of operating system

The operation system of the BLACKBOX (Windows 10 professional) is multi-lingual, i. e. the language can be changed during runtime.

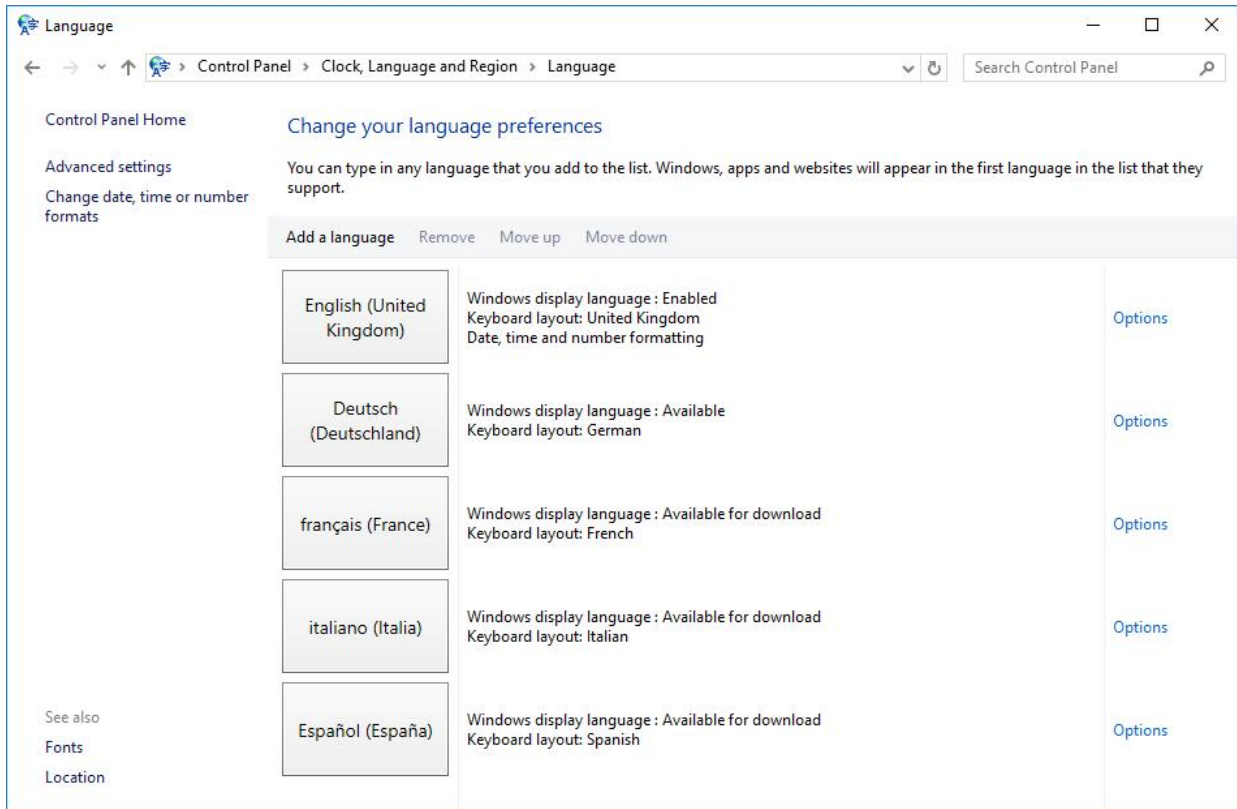

Fig. 3-4 Set up Language

Change the language in *Start / Control Panel / Clock, Language and Region / Language*. Choose the desired language and move it to the top of the list.

Log off the user „Blackbox“ (*Right mouse button on start / Shut or sign out / sign out*). After re-login the user „Blackbox“ (password: Blackbox) the menus and dialogs are displayed in the selected language.

3.4 Watchdog

The BLACKBOX is equipped with a watchdog which monitors the signal recording. In case of an unexpected recording interruption or a computer crash, the watchdog makes sure, that the PLC-ANALYZER pro is stopped and the BLACKBOX is automatically rebooted.

Watchdog is always activated when the PLC-ANALYZER pro 5 is started with the `-watchdog` parameter active (setting in Startup).

There are three ways in which to **disable** the BLACKBOX Watchdog function for maintenance work and remote operation:

- Hold the <Ctrl> key pressed during the boot routine and start of PLC-ANALYZER pro 5 (only with a keyboard which is connected directly).
- Manual termination of signal recording in PLC-ANALYZER pro 5.

- Availability of a PC for remote operation of the BLACKBOX in the network whose IP address (network address) was made known to the PLC-ANALYZER pro 5 during startup with the `-cip:<ip-address>` parameter (refer to *section 4.3*)

3.5 Control LEDs

The BLACKBOX has some control LEDs which are described below.

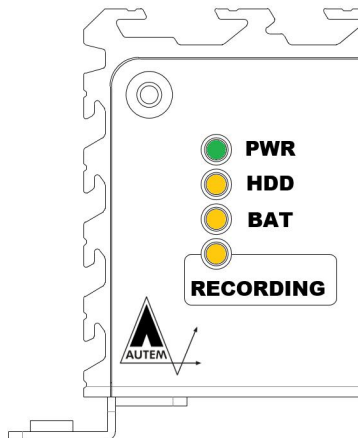

Fig. 3-5 Control-LEDs

LED	Description
PWR	BLACKBOX is running
HDD	Read/write operation on the hard disk
BAT	Voltage of the BIOS backup battery too low. Exchange required.
RECORDING	Flashes at intervals of one second when signal recording is running successfully

Tabelle 3-1 Control-LEDs

4 Operation with *PLC-ANALYZER pro 5*

Before beginning long-term data acquisition, the PLC-ANALYZER pro 5 must be appropriately configured. The most important steps are described, briefly, below. More information on the PLC-ANALYZER pro 5 is available in *PLC-ANALYZER pro 5 User Manual*.



NOTE

The BLACKBOX is equipped with a special version of PLC-ANALYZER pro 5. This version has special features that make an automated operation possible.

4.1 Creating the project for signal recording

Start the PLC-ANALYZER pro 5 and create a project file for recording the signals. The PLC-ANALYZER pro 5 is configured in such a way that the signal recording defined in the project begins automatically after starting the BLACKBOX. Information on the PLC-ANALYZER pro 5 start parameters is provided in *section 4.3*.

For reasons of data integrity, it is recommended to limit the size of the signal files created for long-term recording. We recommend a size of 60 minutes. Select *Project / Project Options / Acquisition Mode* and set *Signalfile Size* to 60 minutes.



NOTE

Avoid large signal files to prevent possible data loss in case of e. g. unexpected powering off the BLACKBOX during data acquisition. Small signal files have additional advantages. They can be transferred more easily during a remote session.

If not specified otherwise, signal files are stored to the hard disk up to 50 GB free space. Thereafter the oldest signal files are being automatically deleted step by step (FIFO ring buffer). With `-d` you can specify a period of time in days, after that the oldest signal file is being deleted gradually (refer to *section 4.3*).

Save the project on the BLACKBOX hard disk in the `c:\blackbox\project` folder under the name `blackbox.prj`.



WARNING

For some types of signal recording (e. g. cycle-precise acquisition) PLC-ANALYZER pro has to modify the PLC program. An influence of this modification on the behaviour of the PLC can not be eliminated entirely. See driver addendum of the PLC driver for further information.

4.2 Start signal recording

- Open c:\blackbox\project and check whether a valid project file blackbox.prj is available.
- Terminate the Windows session and switch the BLACKBOX off.
- Check that the connections to the PLC and power supply are correct. If the BLACKBOX should operate autarkic, disconnect the connections to the keyboard, mouse and screen.
- Switch on the BLACKBOX. The system is booted and signal recording should start, fully automatically, after about 1 minute.
- The RECORDING LED (*see Fig. 4-1*) flashes at intervals of one second when signal recording has been started successfully.
- The system is now active. Signal files are subsequently recorded according to the project settings.
- The bottom status bar of PLC-ANALYZER pro continuously displays the number of *Reboots* caused by watchdog, the *Reconnects*, the *Created signal files*, the *Trigger* and the duration of recording.
- The BLACKBOX enables a practically continuous recording of signals over a very long time. When the capacity has been reached, the oldest signal file is automatically deleted to create space for new signal data.

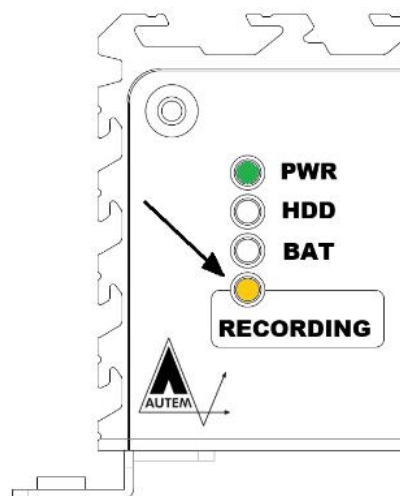

Fig. 4-1 RECORDING LED



NOTE

If the RECORDING LED does not start to flash at intervals of one second after 2 minutes, signal recording has not been started successfully. Also, permanent rebooting of the BLACKBOX ("Beep") indicates that signal recording has not been successfully started.

**NOTE**

We recommend to monitor the LIFE-INDICATOR (s. *section 2.2*) electrically e.g. by integrating it into process visualisation (HMI / SCADA). Thereby the machine operator is informed immediately about a possible interrupt in data acquisition.

**NOTE**

A further means to monitor data acquisition is dispatching status messages via REMOTE-STATUS-INDICATOR. See *section 4.5* for further information.

4.3 Start parameters for *PLC-ANALYZER pro 5*

The PLC-ANALYZER pro 5 is started automatically through an entry in the Windows *Startup* folder after the BLACKBOX has been booted.

The syntax of the PLC-ANALYZER pro 5 start parameters is explained below:

```
anawin [-run] [-watchdog] [-wrд:<minutes>] [-d:<days>] [-cip:<client-IP>] [<projectfile>]
```

Example (BLACKBOX default setting):

```
anawin -run -watchdog -wrд:10 -d:60 -cip:192.168.0.2 blackbox.prj
```

Parameter	Description
-run	Signal recording in the project <projectfile> is started automatically after starting the PLC-ANALYZER pro 5.
-watchdog	Enables the watchdog feature when the PLC-ANALYZER pro 5 is started (also refer to <i>section 0</i>).
-wrд:<minutes>	Delay in minutes the watchdog waits for, until the BLACKBOX is rebooted after an interruption of signal recording. If not specified, the delay time is 5 minutes.
-d:<days>	Specifies the size of the „ring buffer“. Signal files, which are older than the number of days specified, are being deleted. For this, PLC-ANALYZER pro 5 only cares for those signal files, which were created during the current session (also refer to <i>section 4.1</i>)
-cip:<client-IP>	If a PC with this IP address is available in the network on starting the PLC-ANALYZER pro, watchdog is not enabled (also refer to <i>section 0</i>). This can be helpful for maintenance purposes.
<projectfile>	Project file with predefined settings for recording signals.

Table 4-1 PLC-ANALYZER pro 5 start parameters for BLACKBOX

The start parameters can be changed in folder *Startup*. Press the window key  + <R>, enter „shell:common startup“ and click *OK*.

Position the mouse on *PLC-ANALYZER pro 5* and click the right mouse. The start parameters can then be modified in *Properties / Shortcut / Target*.

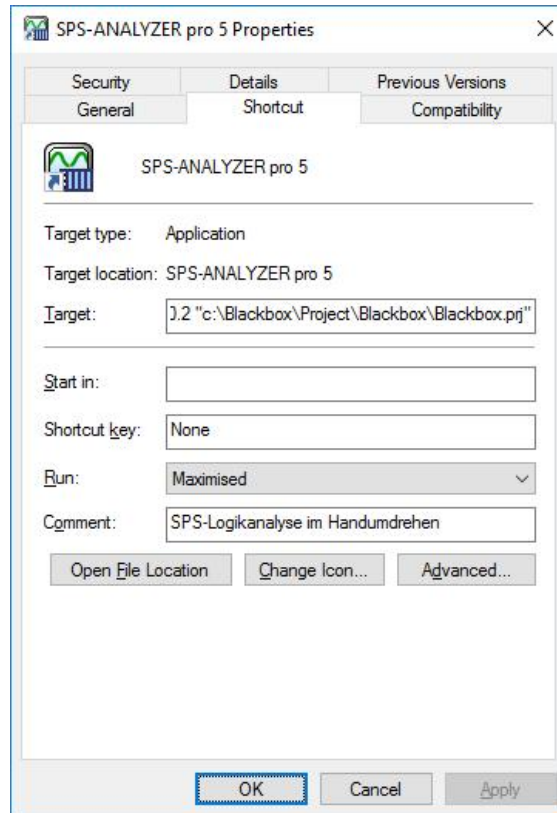

Fig. 4-2 Changing the PLC-ANALYZER pro 5 start parameters

4.4 Reading out recorded signal files

Signal files can be copied at any time from the `c:\blackbox\project` folder - even when signal recording is actually running. For more information on operation, refer to *section 3*.

4.5 Status Messages via REMOTE-STATUS-INDICATOR

It is possible to monitor the operation of the BLACKBOX from a distance. Therefore the PLC-ANALYZER pro 5 for BLACKBOX provides the possibility of dispatching status messages via SMS or E-mail. Besides any text also some different variables (signal- and status values) can be sent.

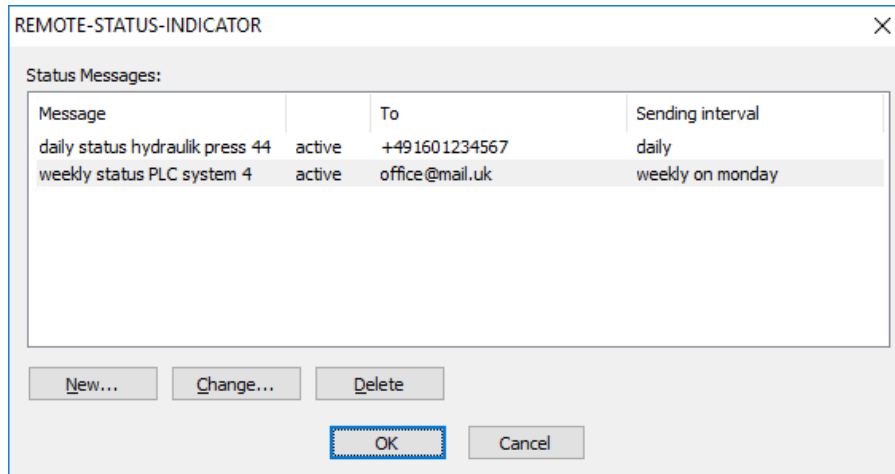

Fig. 4-3 REMOTE-STATUS-INDICATOR - status messages

To create or change a status message choose *REMOTE-STATUS-INDICATOR* in menu *Extras*. The window shows all status messages defined. Inactive status messages are displayed grey.

Click *New* in order to create a new status message. Select *Change* in order to change an existing one.

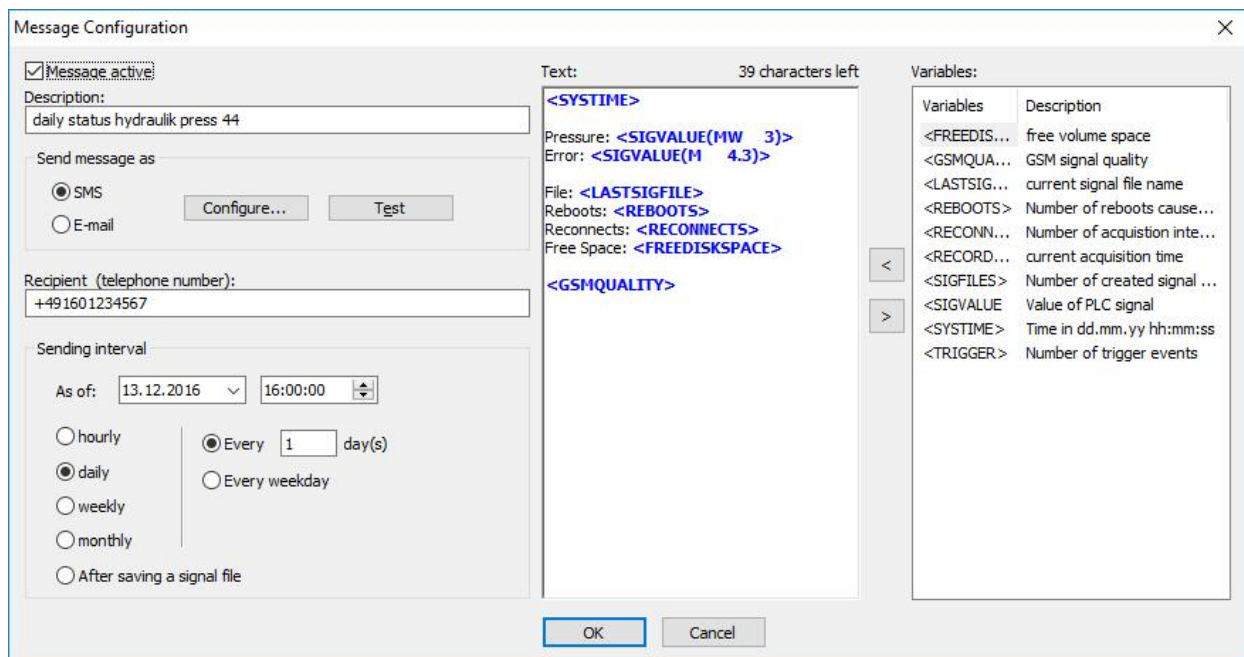

Fig. 4-4 Configure a status message

Choose a meaningful *Description* for the message. Define whether the message should be sent as *SMS* or *E-mail*. Click on *Configure* to select the options for SMS or E-mail dispatching (s. 4.5.1 *Configure SMS* and 4.5.2 *Configure E-mail*).

Enter the the telephone number or the E-mail address of the *Recipient* of the status message.

To ensure that all settings are correct, press *Test* in order to send the SMS or E-mail for evaluation purposes to the recipient.

Adjust the *Sending interval* accordingly.



NOTE

Pay attention to the fact that high costs may incur depending on sending interval and transmission path.

Enter the message in the textbox *Text*. Besides normal text also variables can be used. Drag the desired variable (s. Table 4-2 status variables) from the list of *Variables* to the textbox or use and .

Variable	Description
<FREEDISKSPACE>	Free space on current disk drive
<GSMQUALITY>	GSM signal strength (0 - 100 %)
<LASTSIGFILE>	Current signal file name
<REBOOTS>	Number of BLACKBOX reboots (watchdog)
<RECONNECTS>	Number of reconnects after acquisition interrupt
<RECORDTIME>	Current duration of acquisition
<SIGFILES>	Number of created signal files
<SIGVALUE(X)>	Current value of PLC signal X
<SYSTIME>	System time and date in the time of message dispatching
<TRIGGER>	Number of trigger events

Table 4-2 status variables

An SMS status message is limited to 160 characters. The size of an E-mail status message is not limited.

After configuration of a status message, you can activate the message with check box *Message active*. Otherwise the configured message is only stored for now. The message can be activated anytime later.

Accept the settings with *OK*. All active status messages are now dispatched with the specified *Sending Interval*.

4.5.1 Configure SMS dispatching

Fig. 4-5 SMS settings

Choose the device over which the SMS should be dispatched. The installation of a modem (GSM/UMTS/LTE) is required for that.

Select the *SMS Center*. You can use *SIM card settings* or *enter manually*. If you choose *enter manually* type in the number of the SMS Center. If necessary enter the *MSN* number and activate *Modem at an extension line*, if your modem/ISDN adapter is connected to an extension line. If applicable enter also the exchange code.

Confirm with *OK*.

4.5.2 Configure E-mail dispatching

Fig. 4-6 E-mail settings

Choose, whether E-mails should be dispatched by installed *standard mail program* (e.g. Outlook) or by *SMTP-Server*. For dispatching by *SMTP-Server* you must specify, whether the connection to SMTP-Server should be established via *LAN* or *Modem*.

A suitable dial-up connection is assumed. See windows help for more information on how to set up a dial-up connection.

Besides *SMTP-Server* address enter also the *forwarder e-mail address*. If necessary enter a *user name* and a *password*. Click on the corresponding checkbox if the SMTP-server requires a secure connection (SSL).

Confirm with *OK*.

5 Troubleshooting (FAQ)

This chapter provides hints for troubleshooting the BLACKBOX.

Symptom	Help
BLACKBOX reboots permanently	Reason: The watchdog is enabled and signal recording could not be established successfully. Disable the watchdog (see <i>0 Watchdog</i>), if you want to do maintenance work. Check the connection with the PLC, if the problem occurs during data recording. More information about the configuration of data recording, see <i>user manual PLC-ANALYZER pro 5</i> .

Table 5-1 Troubleshooting